

C1030 – 1000 lb Cube Ice Machine

Prodigy™ Modular Cube Ice Maker



Shown on BH801S-A bin.

Features

Prodigy™ cubers use **significantly less energy and water** than other cube ice machines, exceeding pending California and Federal energy efficiency regulations.

Auto-Alert™ indicator lights constantly communicate about operating status and actually signal your staff when it's time to descale, sanitize, and more—making upkeep practically foolproof.

The patented **WaterSense™ adaptive purge control** delivers maximum reliability by reducing scale buildup for a longer time between cleanings.

Preventative maintenance is simpler than ever with easily-removed panels allowing clear access to internal components and a diagnostic code display insuring the right fix the first time. Reusable air filter is easily removable from the outside.

All external panel components are crafted for **optimal aesthetic appeal** through superior fit and finish.

An optional **advanced feature SmartBoard™** provides NAFEM data protocol and additional operational data that can be displayed on-screen or transmitted remotely, resulting in early alert and fast diagnosis of operating issues.

An optional **Vari-Smart™ ultrasonic ice level control** sensor allows you flexibility to program ice levels, for up to 7 days, keeping just the right amount of freshly made ice in the bin.

24 Hour Volume Production

Air Cooled			Remote			Water Cooled		
70°F/21°C 50°F/10°C lb/kg	Air Water	ARI 90°F/32°C 70°F/21°C lb/kg	70°F/21°C 50°F/10°C lb/kg	Air Water	ARI 90°F/32°C 70°F/21°C lb/kg	70°F/21°C 50°F/10°C lb/kg	Air Water	ARI 90°F/32°C 70°F/21°C lb/kg
1077/490		844/384	996/453		851/387	1009/459		908/413

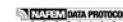

Modular Bin Options

* Stainless Steel with Galvanized Back & Bottom.

Model Number	Dimensions W" x D" x H"	ARI Certified Bin Capacity lb/kg	Application Capacity lb/kg	Finish	Ship Weight lb/kg
B842S	42 x 34 x 44	610/277	778/353	SS	185/84
B948S	48 x 34 x 44	700/319	893/406	SS	220/100
BH1100BB	48 x 34 x 50	860/390	1100/499	SS w/ GBB*	280/127
BH1100SS	48 x 34 x 50	860/390	1100/499	SS	280/127



Bin: BH1100SS

Cube Ice



Small Cube
3/8" x 3/8" x 3/8"
(2.22 x 2.22 x .95 cm)

Medium Cube
7/8" x 7/8" x 7/8"
(2.22 x 2.22 x 2.22 cm)

Common ice form, ideal for mixed drinks.

Warranty

- 3 years parts and labor on all components.
- 5 years parts and labor on the evaporator.
- 5 years parts on the compressor and condenser.

Warranty valid in North, South & Central America. Contact factory for warranty in other regions.

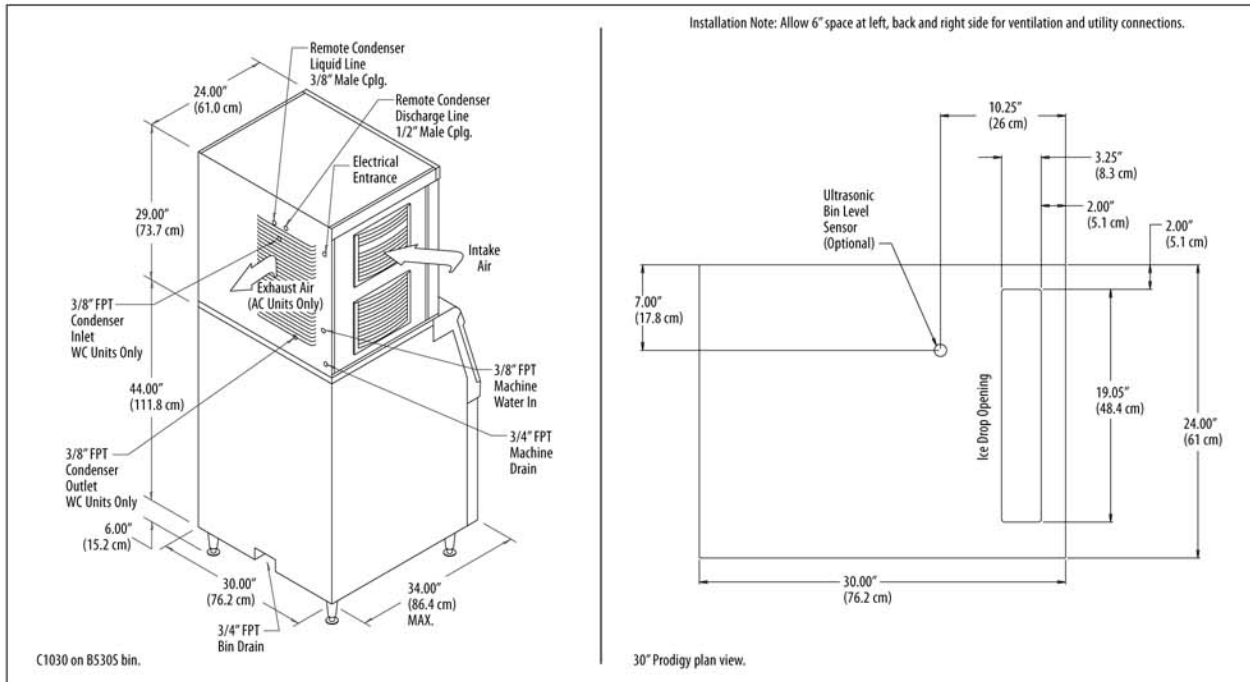

Specifications

Model Number* <small>Cube Size: medium or small</small>	Condenser Unit	Basic Electrical Volts/Hz/Phase	Max. Fuse Size or HACR Circuit Breaker (amps)	Circuit Wires	Min. Circuit Ampacity	Energy Consumption kWh/100 lb (45.4 kg) 90°F(32°C)/70°F(21°C)	Water Usage Gallons/100 lb (liters/45.4 kg)	
							Potable 90°F(32°C)/ 70°F(21°C)	Condenser 90°F(32°C)/ 70°F(21°C)
pair C1030MA-32A C1030MR-32A C1030MW-32A	Air	208-230/60/1	20	2	16.0	5.0	18.4/69.8	-
	Remote	208-230/60/1	20	2	15.8	5.0	18.2/69.0	-
	Water	208-230/60/1	15	2	14.8	4.0	19.7/74.7	153.0/580.1
us C1030SA-32A C1030SR-32A C1030SW-32A	Air	208-230/60/1	20	2	16.0	5.0	18.4/69.8	-
	Remote	208-230/60/1	20	2	15.8	5.0	18.2/69.0	-
	Water	208-230/60/1	15	2	14.8	4.0	19.7/74.7	153.0/580.1

* 208-230/60/3 Voltage - Substitute *-3\"/>

All Models

Dimensions (W x D x H):
Unit:
30\"/>

Shipping Carton:
33.5\"/>

Shipping Weight:
235 lb / 107 kg

BTUs per hour:
16,200

Accessories

Model Number	Description
KVS	Vari-Smart™ Ice Level Control - Program ice bin levels to match ice needs.
KSB	Smart-Board™ Advanced Control - Use additional operational data for fast diagnosis.
KSB-N	Smart-Board™ Advanced Control with Network - Network capable.
ERC311-32A	Remote Condenser for C1030xR, 208-230/60/1 - Consult Remote Condenser Spec Sheet for details.
RTE10	Line set, Precharged, R-404A, 10ft.
RTE25	Line set, Precharged, R-404A, 25ft.
RTE40	Line set, Precharged, R-404A, 40ft.
RTE75	Line set, Precharged, R-404A, 75ft.

* Scotsman recommends all ice machines have water filtration. See Scotsman Sanitation Matrix for details.

Operating Requirements

	Minimum	Maximum
Air Temperatures	50°F (10°C)	100°F (38°C)
Water Temperatures	40°F (4.4°C)	100°F (38°C)
Remote Cond. Temps	-20°F (-29°C)	120°F (49°C)
Water Pressures	20 PSIG (1.4 bar)	80 PSIG (5.5 bar)
Electrical Voltage	-5%	+10%

Specifications and design are subject to change without notice.